

# GME

# QUICK GUIDE

This document is a concise version of the model manual. This document is not meant to be a replacement of the manual. To download the full manual please scan the QRcode below or locate the data label on the model and scan the QRcode.

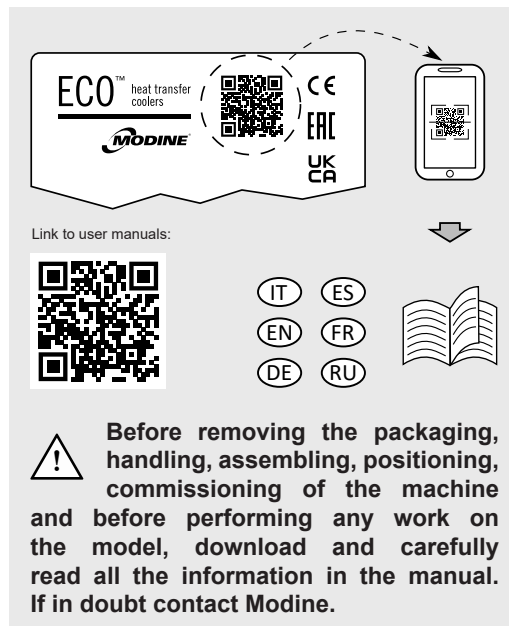
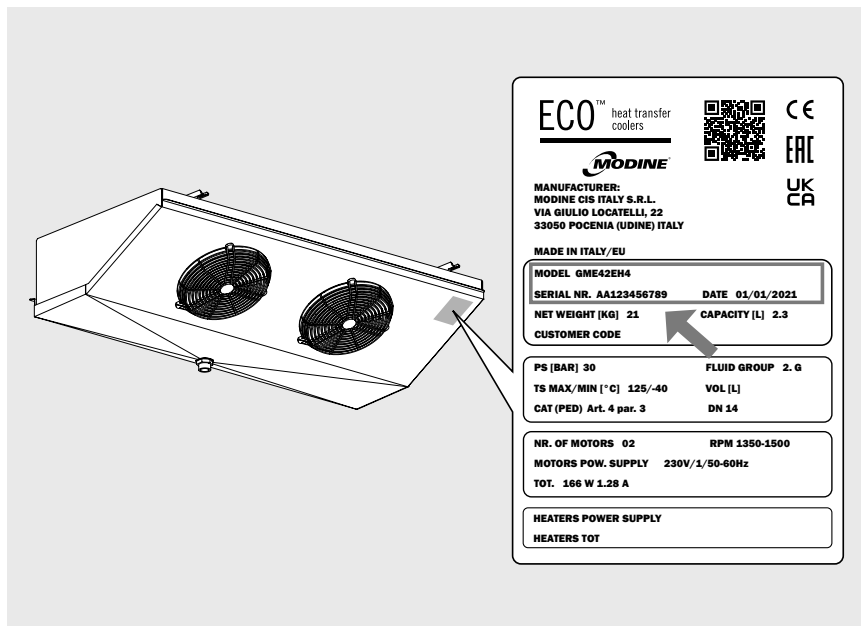

## Construction and dimensional features

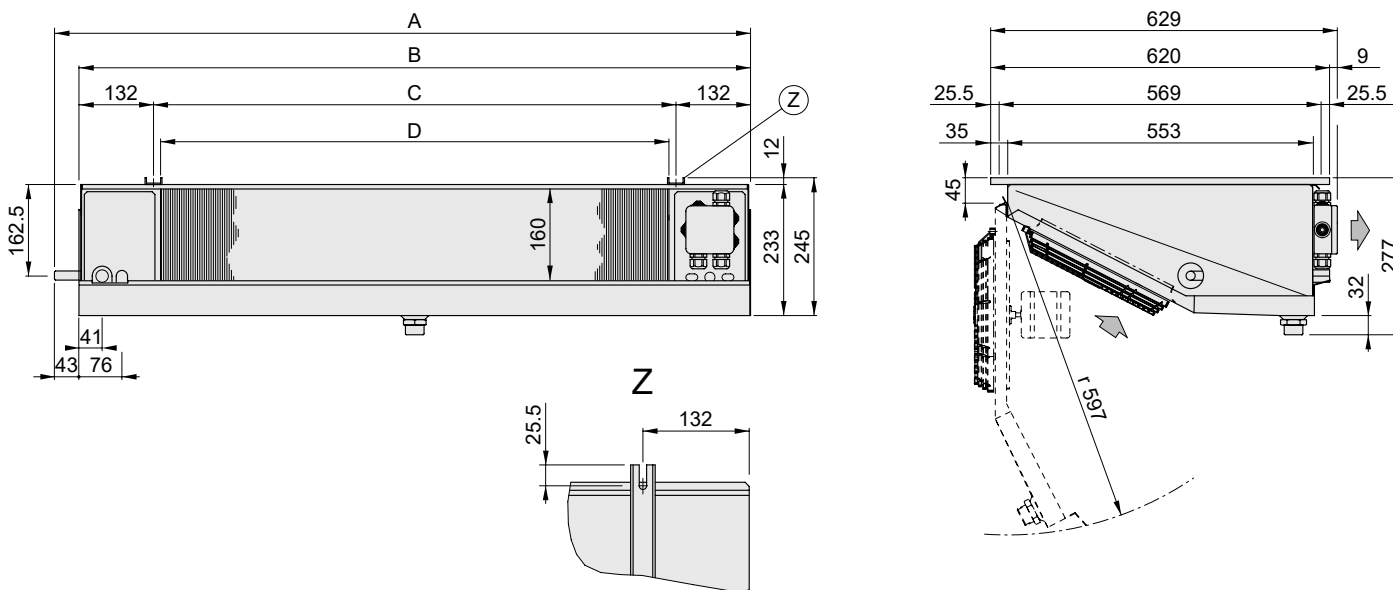

Model	GME	41GH4	41EH4	41FL7	42GH4	42EH4	-	42FL7	43GH4	43EH4	43FL7	44GH4	44EH4	44FL7
		41GL7	41EL7	-	42GL7	-	42EL7	-	-	43EL7	-	-	44EL7	-
Motorfans	n° x Ø mm	1x250	1x250	1x250	2x250	2x250	2x250	2x250	3x250	3x250	3x250	4x250	4x250	4x250
Dimensions	A	782	782	782	1232	1232	1232	1232	1682	1682	1682	2132	2132	2132
	B	739	739	739	1189	1189	1189	1189	1639	1639	1639	2089	2089	2089
	C	475	475	475	925	925	925	925	1375	1375	1375	1825	1825	1825
	D	451	451	451	901	901	901	901	1351	1351	1351	1801	1801	1801
Coil connections	In (mm)	12	12	12	12	12	12	12	12	12	12	12	12	12
	Out (mm)	16	16	16	16	16	22	22	16	22	22	22	22	22
Drain connection	Ø (GAS)	1"	1"	1"	1"	1"	1"	1"	1"	1"	1"	1"	1"	1"
Net weight	kg	12	13	13	19	21	20	21	25	27	28	32	35	35

XXXXXX : Thermostatic valve with external pressure equaliser recommended

## Inspection - Storage







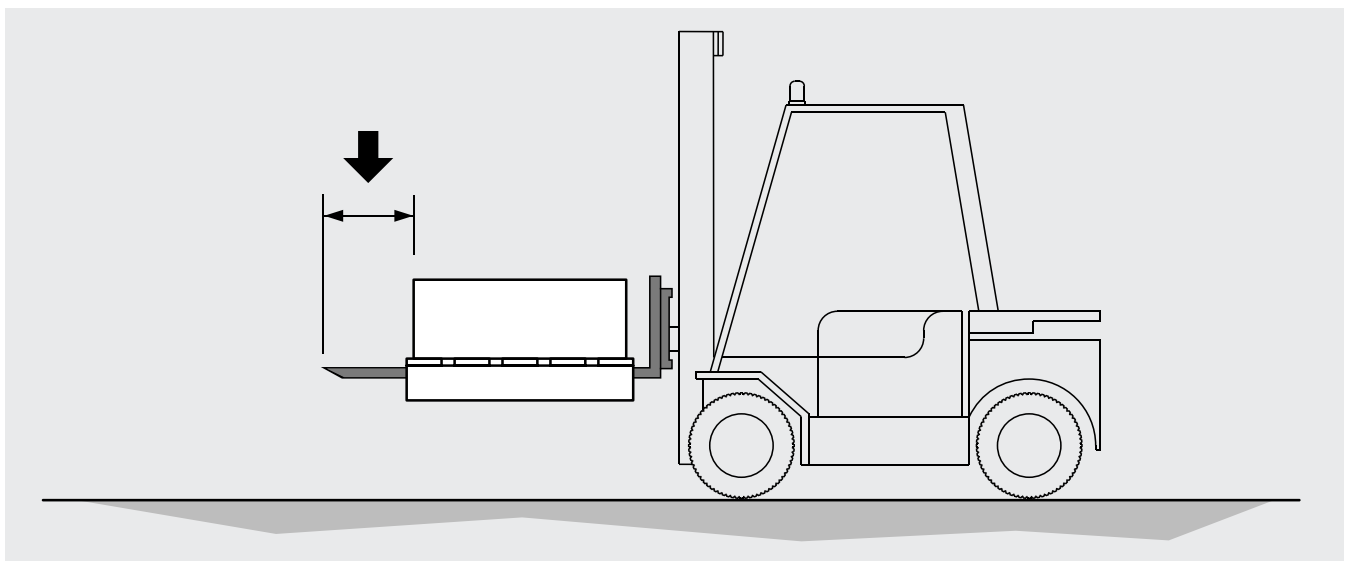

- 1.1 Upon receipt of the model immediately check its state of integrity; immediately dispute with the transport company any damage. The packaging is created according to the model, to the suitable means of transport and of handling.
- 1.2 The model must be stored in its original packaging in a place that is protected and away from weathering.
- 1.3 Do not place any other material on top of the packaging.
- 1.4 If the model is allowed to be stacked, follow the instructions on the packaging.
- 1.5 If a motor fan is switched OFF for a long period of time, it must be switched ON for at least 2 hours every month to remove any traces of condensation that may have formed inside the motor.
- 1.6 The following rules apply when the unit must remain in storage for long periods of time. The unit must be stored indoors and positioned according to the instructions on the package. During storage, the fans must be manually rotated at least once every 3 months.

## Handling and installation

- 1.7 The models are supplied in a cardboard box and/or wooden cage.
- 1.8 The packaged model must be moved by qualified personnel using a forklift truck of suitable capacity, or with crane and/or overhead crane. The lifting brackets must be longer than the depth of the packaging and/or of the model. Avoid any abrupt movement and do not stand close to the manoeuvring area. Always ensure that the models are secured to the hoists before handling operations. A heavy impact or a strong thrust can overturn the model.
- 1.9 The model must always be kept in position as indicated on the packaging.
- 1.10 Avoid applying improper pressure to the packaging during handling. Take care not to damage the headers.
- 1.11 Unpack the unit close to the installation site.
- 1.12 Always use PPE (Personal Protection Equipment) during handling and installation, e.g. gloves that are sufficiently resistant to mechanical hazards, to reduce the risk of injury in the event of contact with sharp sheet metal edges or the finned pack.
- 1.13 It is essential to take all the necessary measures to ensure the complete safety of the operators in order to prevent the model from accidentally falling against people. It is forbidden to work under a suspended load. It is advisable to prepare a structure of greater capacity than the weight to be supported (trestle or props) on which to place the model.
- 1.14 When installation is complete, remove the protective film covering the model.
- 1.15 When installation is complete, dispose of packaging according to local regulations.
- 1.16 If brackets are provided, install and maintain them for future use.



- 1.17 The following table summarises the PPE (Personal Protection Equipment) to be used during the various phases of the life of the equipment (each stage involves the obligation to use and provide PPE), in order to protect the health and safety of operators.
- 1.18 The responsibility for the identification and choice of the type and category of PPE that is appropriate and suitable lies with the user.
- 1.19 The PPE used must comply with the directives of the product and bear the CE marking (for the European market).

Phase								
	Protective clothing	Safety footwear	Gloves	Goggles	Visor	Ear protectors	Mask	Helmet or head gear
Transportation	NP	NP	NP	NP	NP	NP	NP	NP
Handling	X	X	X	X	NP	NP	NP	X
Unpacking	X	X	X	X	NP	NP	NP	X
Assembly	X	X	X	X	NP	O	NP	X
Ordinary use	NP	NP	NP	NP	NP	NP	NP	NP
Adjustments	X	X	X	NP	X	O	NP	NP
Cleaning	X	X	X	NP	X	O	X	NP
Maintenance	X	X	X	NP	X	O	O	X
Dismantling	X	X	X	NP	X	O	NP	X
Demolition	X	X	X	X	NP	O	NP	O

X : Recommended PPE

O : PPE available or to be used if necessary

NP : PPE not recommended

## Wiring diagrams

### Motor-fan connection diagram

**Important. The motors are equipped with inner thermal protection with automatic reconnection. Before using motor speed control systems verify the compatibility with the motors. Non compatible systems may damage motors or increase noise level; Modine will not be responsible for model performance with speed control systems. For fans equipped with thermal contacts (TK), these must be connected to the control circuit. For models supplied with wiring in a junction box, remove the cover to make the connection.**

Model	GME	41GH4	41FL7	42GH4	42FL7	43GH4	43FL7	44GH4	44FL7
		41GL7	-	42GL7	-	-	-	-	-
41EH4	-	42EH4	-	43EH4	-	44EH4	-	-	
41EL7	-	42EL7	-	43EL7	-	44EL7	-	-	

Motorfans	n° x Ø mm	1x250		2x250		3x250		4x250	
Frequency	Hz	50	60	50	60	50	60	50	60
Electrical consumption	A	0.64	0.64	1.28	1.28	1.92	1.92	2.56	2.56
	W	83	83	166	166	249	249	332	332
RPM		1350	1500	1350	1500	1350	1500	1350	1500

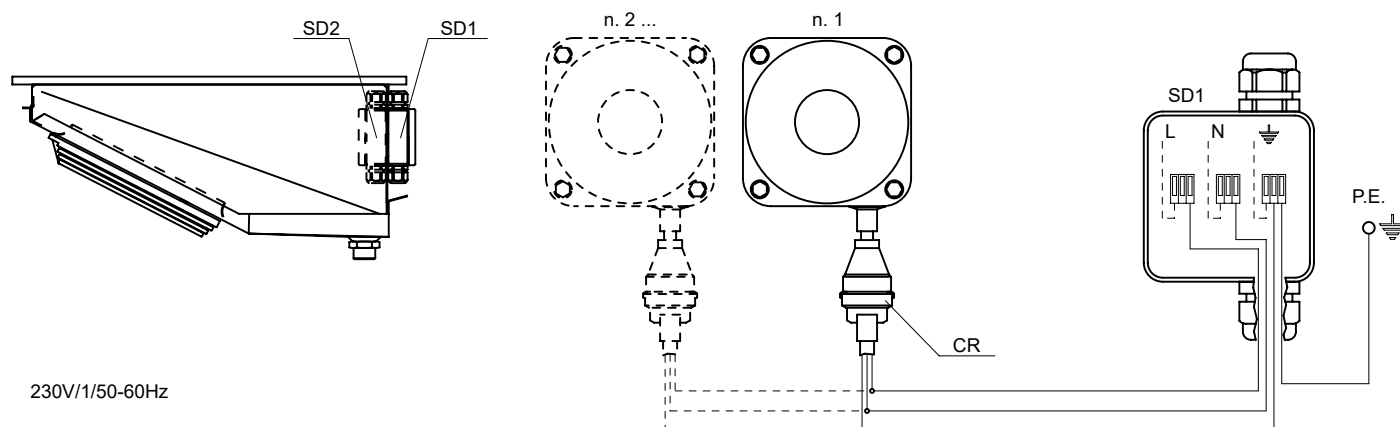

230V/1/50-60Hz

-  = yellow-green
- L = brown or grey
- N = blue
- SD1 = motorfan junction box
- SD2 = heater junction box
- CR = cable quick connection

## Checks to be performed before start-up

With main switch open and padlocked ("0-OFF" position):

- 1.1 Tightening of all the electrical connections.
- 1.2 Levelling and checking the solidity of the supporting structure.
- 1.3 Correct fastening of panels and components, paying particular attention to the correct fastening of the fan guard grille.
- 1.4 Verification of spaces for maintenance.
- 1.5 Correspondence of the supply voltage to the plate data.
- 1.6 Freedom of movement of the blades of the fans.
- 1.7 Absence of fluid leaks. Risk of environmental damage.
- 1.8 Removal of the protective film from the casing.
- 1.9 Checking of the cleanliness of the installation area.
- 1.10 Check that there are no foreign bodies in the vicinity of the fans and of the unit to avoid them being sucked in by the fans.
- 1.11 Checking of the pressure tightness of the unit.
- 1.12 The unit is ready for use after all the instructions and warnings concerning the electrical connections and the fluids have been strictly adhered to.

## Checks to be performed after start-up

- 1.1 The first start-up must be supervised by a qualified technician and must be carried out with great care.
- 1.2 Check the rotation direction of the motor fans. Contrary rotation could affect the performance of the model.
- 1.3 Check freedom of rotation of the impeller, without rubbing or irregular movements.
- 1.4 Check the movement of the fluid.
- 1.5 Absence of vibrations or unusual noises.
- 1.6 Check that the electric consumption is correct, in any case not exceeding what is reported on the label of the motor fan. If the unit is equipped with defrosting heaters, check that the consumption complies with the data in the table (see Manual).
- 1.7 Check that the screws are tightened correctly (Ref. EN 1090-2).



Modine CIS Italy S.r.l.  
33050 Pocenia - Udine - Italy  
Via Giulio Locatelli, 22  
Tel. +39 0432.772.001  
Fax +39 0432.779.594  
www.modine.com

Link to user manuals:

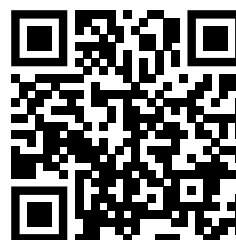

<https://www.modinecoolers.com/documents/>