

ECOTM heat transfer
coolers



GCE \varnothing 450mm
UNIT COOLERS



Engineering a Cleaner, Healthier World

GCE Ø450mm UNIT COOLERS

The range of GCE cubic air coolers is expanding today with models equipped with Ø 450 mm fans to better adapt to low/mid size refrigeration industrial plants dedicated to the preservation of fresh and frozen products.

The range is equipped with new high-efficiency heat exchangers, made with aluminum fins and special copper tubes. Available fin spacings are 4, 6, 8 and 10 mm. The new geometry allows a substantial reduction of the inner volume resulting in decreased refrigerant use.

GCE employs two types of fans motors:

STANDARD

- Ø 450 mm single-phase 230V/1/50-60Hz external rotor with epoxy painted steel grid;
- protection grade: IP 54;
- class F insulation;
- internal protective thermal contact;
- operating temperature: -40 to +60 °C.

EC

- Ø 450 mm single-phase 230V/1/50-60Hz external rotor with epoxy painted steel grid;
- protection grade: IP 54;
- class B insulation;
- integrated electronic protection;
- operating temperature: -25 to +70 °C.

The versions with standard electric defrost (ED) are equipped with stainless steel heaters with vulcanised terminals preset for 400V/3/50-60Hz connection.

The electric parts and casing are connected to a ground terminal, the wiring of the heaters is carried out in IP 54 protection grade junction box. On request the models can be equipped with non-standard: coils, defrosting and fan motors.

For special applications and additional information, please contact our "Coolers Application Engineering" team.

New GCE Ø 450 mm capacity:
from 4,7 to 38,3 kW (R448A, wet conditions)

Scelte
SELECTION SOFTWARE

www.modineselect.com

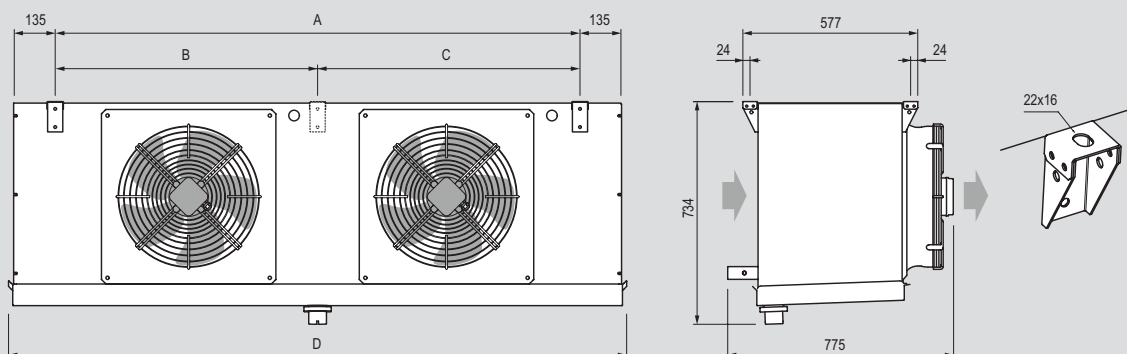

Number of fan motors		1	2	3	4
Dimensions mm	A	1188	2038	2888	3738
	B	880	1730	2580	3430
	C	-	-	-	1700
	D	-	-	-	1730

Modine Manufacturing Company

Modine CIS Italy S.r.l.
Via Giulio Locatelli, 22
33050 Pocenia (UD) Italy

©2026 Modine Manufacturing Co.



www.modinecoolers.com