

IDE

QUICK GUIDE

This document is a concise version of the model manual. This document is not meant to be a replacement of the manual. To download the full manual please scan the QRcode below or locate the data label on the model and scan the QRcode.

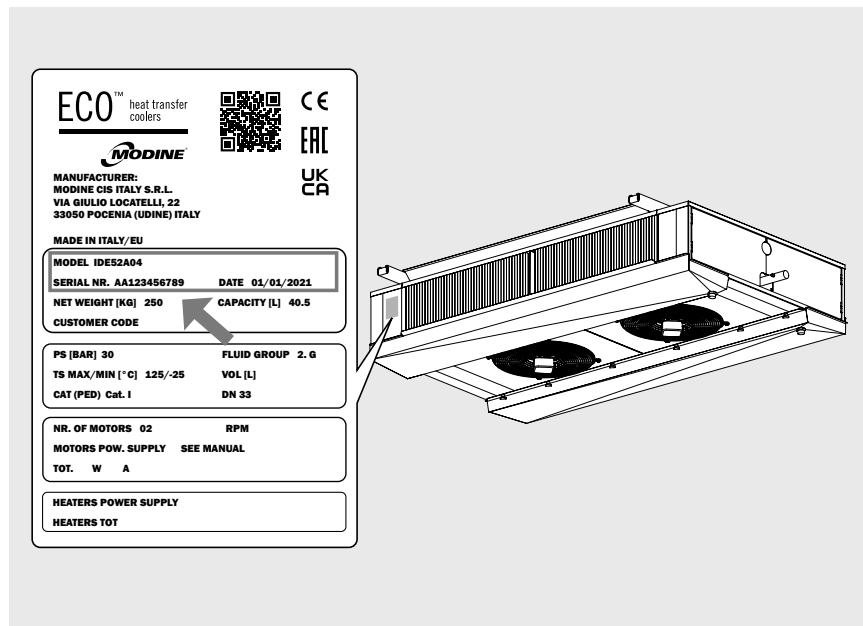

Construction and dimensional features

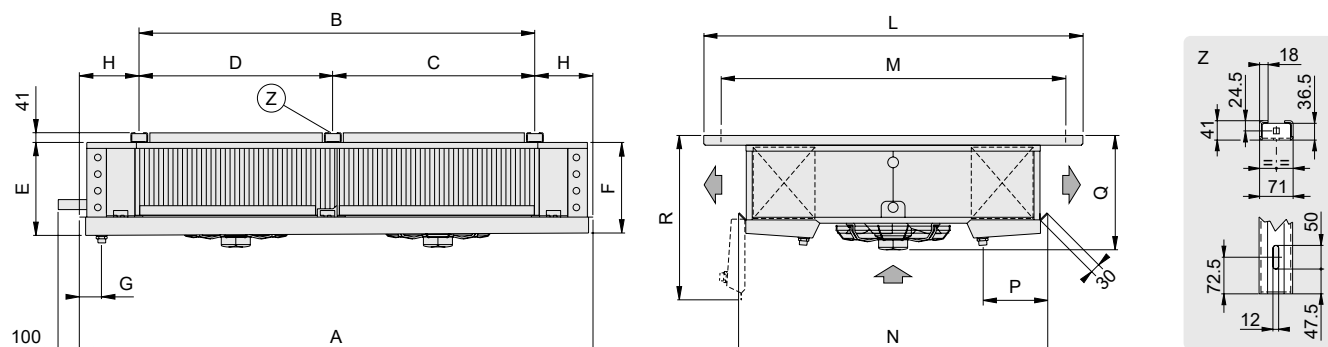

Model	IDE	41A04	41B04	42A04	42B04	43A04	43B04	52A04	52B04	53A04	53B04	54A04	54B04
		41A07	41B07	42A07	42B07	43A07	43B07	52A07	52B07	53A07	53B07	54A07	54B07
		41A10	41B10	42A10	42B10	43A10	43B10	52A10	52B10	53A10	53B10	54A10	54B10
Motorfans	n° x Ø mm	1 x 450		2 x 450		3 x 450		2 x 560		3 x 560		4 x 560	
	A	1300		2150		3000		2760		3860		4960	
	B	814		1664		2514		2164		3264		4364	
	C	-		-		1700		1100		2 x 1100		3 x 1100	
	D	-		-		814		1064		1064		1064	
	E	406		410		415		538		543		550	
	F	400		400		400		530		530		530	
	G	85		85		85		90		90		90	
Dimensions	H	243		243		243		298		298		298	
	L	1594		1594		1594		1809		1809		1809	
	M	1449		1449		1449		1664		1664		1664	
	N	1290		1290		1290		1505		1505		1505	
	P	280		280		280		280		280		280	
	Q	490		490		490		680		680		680	
	R	695		695		695		835		835		835	
Coil connections	In (mm)	16		22		28		28		35		35	
	Out (mm)	35		42		42		54		54		70	
Drain connection	Ø (GAS)	2 x 1"		2 x 1"		2 x 1"		2 x 2"		2 x 2"		2 x 2"	
Net weight	kg	80		145		206		250		370		498	

Thermostatic valve with external pressure equaliser recommended

Inspection - Storage

- 1.1 Upon receipt of the model immediately check its state of integrity; immediately dispute with the transport company any damage. The packaging is created according to the model, to the suitable means of transport and of handling.
- 1.2 The model must be stored in its original packaging in a place that is protected and away from weathering.
- 1.3 Do not place any other material on top of the packaging.
- 1.4 If the model is allowed to be stacked, follow the instructions on the packaging.
- 1.5 If a motor fan is switched OFF for a long period of time, it must be switched ON for at least 2 hours every month to remove any traces of condensation that may have formed inside the motor.
- 1.6 The following rules apply when the unit must remain in storage for long periods of time. The unit must be stored indoors and positioned according to the instructions on the package. During storage, the fans must be manually rotated at least once every 3 months.

Handling and installation

- 1.1 The models are supplied in a cardboard box and/or wooden cage.
- 1.2 The packaged model must be moved by qualified personnel using a forklift truck of suitable capacity, or with crane and/or overhead crane. The lifting brackets must be longer than the depth of the packaging and/or of the model. Avoid any abrupt movement and do not stand close to the manoeuvring area. Always ensure that the models are secured to the hoists before handling operations. A heavy impact or a strong thrust can overturn the model.
- 1.3 The model must always be kept in position as indicated on the packaging.
- 1.4 Avoid applying improper pressure to the packaging during handling. Take care not to damage the headers.
- 1.5 Unpack the unit close to the installation site.
- 1.6 Always use PPE (Personal Protection Equipment) during handling and installation, e.g. gloves that are sufficiently resistant to mechanical hazards, to reduce the risk of injury in the event of contact with sharp sheet metal edges or the finned pack.
- 1.7 It is essential to take all the necessary measures to ensure the complete safety of the operators in order to prevent the model from accidentally falling against people. It is forbidden to work under a suspended load. It is advisable to prepare a structure of greater capacity than the weight to be supported (trestle or props) on which to place the model.
- 1.8 When installation is complete, remove the protective film covering the model.
- 1.9 When installation is complete, dispose of packaging according to local regulations.
- 1.10 If brackets are provided, install and maintain them for future use.

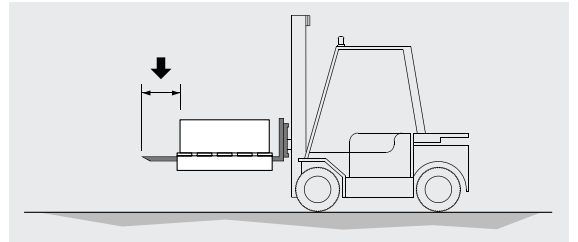



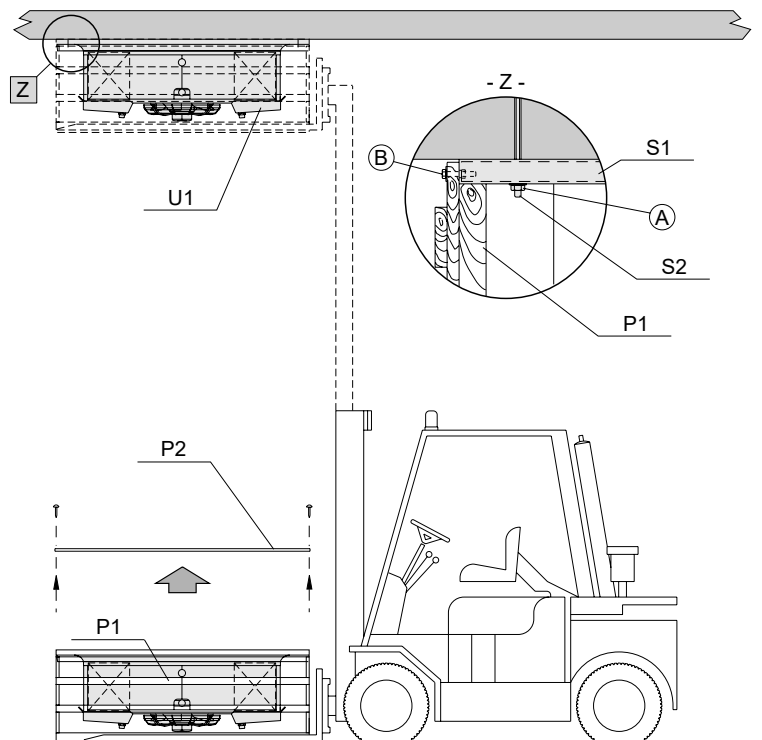





- 1.11 Instructions for ceiling installation:
 - 1.11.1 Remove package lid P2.
 - 1.11.2 Set fastening rods S2 into ceiling.
 - 1.11.3 Lift packaged model to ceiling.
 - 1.11.4 Tighten nuts A to fastening rods S2.
 - 1.11.5 Unfasten and remove safety screws B and slip down empty packaging.
 - 1.11.6 Tighten fastening nuts A of model U1 up to ceiling.



- | | | |
|----|---|-----------------|
| S1 | = | Support bracket |
| S2 | = | Fastening rod |
| P1 | = | Package |
| P2 | = | Package lid |
| U1 | = | Model |

- 1.12 The following table summarises the PPE (Personal Protection Equipment) to be used during the various phases of the life of the equipment (each stage involves the obligation to use and provide PPE), in order to protect the health and safety of operators.
- 1.13 The responsibility for the identification and choice of the type and category of PPE that is appropriate and suitable lies with the user.
- 1.14 The PPE used must comply with the directives of the product and bear the CE marking (for the European market).

Phase								
	Protective clothing	Safety footwear	Gloves	Goggles	Visor	Ear protectors	Mask	Helmet or head gear
Transportation	NP	NP	NP	NP	NP	NP	NP	NP
Handling	X	X	X	X	NP	NP	NP	X
Unpacking	X	X	X	X	NP	NP	NP	X
Assembly	X	X	X	X	NP	O	NP	X
Ordinary use	NP	NP	NP	NP	NP	NP	NP	NP
Adjustments	X	X	X	NP	X	O	NP	NP
Cleaning	X	X	X	NP	X	O	X	NP
Maintenance	X	X	X	NP	X	O	O	X
Dismantling	X	X	X	NP	X	O	NP	X
Demolition	X	X	X	X	NP	O	NP	O

X : Recommended PPE

O : PPE available or to be used if necessary

NP : PPE not recommended

Wiring diagrams

Motor-fan connection diagram

Important. The motors are equipped with inner thermal protection with automatic reconnection. Before using motor speed control systems verify the compatibility with the motors. Non compatible systems may damage motors or increase noise level; Modine will not be responsible for model performance with speed control systems. For fans equipped with thermal contacts (TK), these must be connected to the control circuit. For models supplied with wiring in a junction box, remove the cover to make the connection.

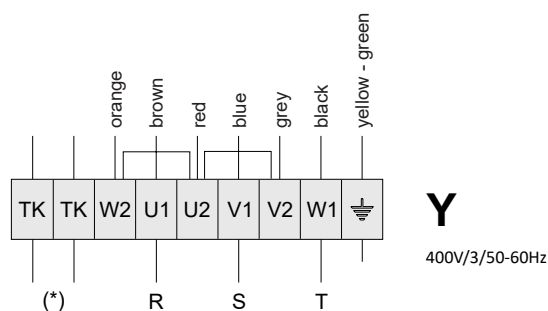
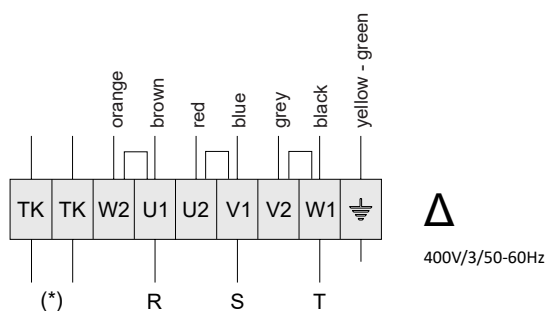

Model	IDE	41A04	41B04	42A04	42B04	43A04	43B04	52A04	52B04	53A04	53B04	54A04	54B04
		41A07	41B07	42A07	42B07	43A07	43B07	52A07	52B07	53A07	53B07	54A07	54B07
		41A10	41B10	42A10	42B10	43A10	43B10	52A10	52B10	53A10	53B10	54A10	54B10
Motorfans	n° x Ø mm	1x450		2x450		3x450		2x560		3x560		4x560	
Frequency	Hz	50		50		50		50		50		50	
Electrical consumption (high speed, Δ)	A	0.79		1.58		2.37		3.30		4.95		6.60	
	W	430		860		1290		1680		2520		3360	
RPM (high speed, Δ)		1370		1370		1370		1360		1360		1360	
Electrical consumption (low speed, Y)	A	0.53		1.06		1.59		2.10		3.15		4.20	
	W	330		660		990		1280		1920		2560	
RPM (low speed, Y)		1030		1030		1030		1090		1090		1090	

Checks to be performed before start-up

With main switch open and padlocked ("0-OFF" position):

- 1.15 Tightening of all the electrical connections.
- 1.16 Levelling and checking the solidity of the supporting structure.
- 1.17 Correct fastening of panels and components, paying particular attention to the correct fastening of the fan guard grille.
- 1.18 Verification of spaces for maintenance.
- 1.19 Correspondence of the supply voltage to the plate data.
- 1.20 Freedom of movement of the blades of the fans.
- 1.21 Absence of fluid leaks. Risk of environmental damage.
- 1.22 Removal of the protective film from the casing.
- 1.23 Checking of the cleanliness of the installation area.
- 1.24 Check that there are no foreign bodies in the vicinity of the fans and of the unit to avoid them being sucked in by the fans.
- 1.25 Checking of the pressure tightness of the unit.
- 1.26 The unit is ready for use after all the instructions and warnings concerning the electrical connections and the fluids have been strictly adhered to.

Checks to be performed after start-up

- 1.27 The first start-up must be supervised by a qualified technician and must be carried out with great care.
- 1.28 Check the rotation direction of the motor fans. Contrary rotation could affect the performance of the model.
- 1.29 Check freedom of rotation of the impeller, without rubbing or irregular movements.
- 1.30 Check the movement of the fluid.
- 1.31 Absence of vibrations or unusual noises.
- 1.32 Check that the electric consumption is correct, in any case not exceeding what is reported on the label of the motor fan. If the unit is equipped with defrosting heaters, check that the consumption complies with the data in the table (see Manual).
- 1.33 Check that the screws are tightened correctly (Ref. EN 1090-2).



Modine CIS Italy S.r.l.
33050 Pocenia - Udine - Italy
Via Giulio Locatelli, 22
Tel. +39 0432.772.001
Fax +39 0432.779.594
www.modine.com

Link to user manuals:

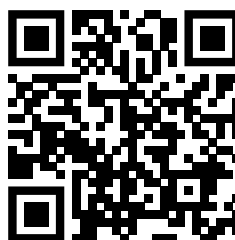

<https://www.modinecoolers.com/documents/>